

REINHOLD ENVIRONMENTAL Ltd.



# **2017 NO<sub>x</sub>-Combustion-CCR Round Table Presentation**

February 27 & 28, 2017, in Cleveland, OH / Hosted by FirstEnergy

All presentations posted on this website are copyrighted by Reinhold Environmental, Ltd (RE). Any unauthorized downloading, attempts to modify or to incorporate into other presentations, link to other websites, or obtain copies for any other uses than the training of attendees to RE's Conferences is expressly prohibited, unless approved in writing by RE or the original presenter. RE does not assume any liability for the accuracy or contents of any materials contained in this library which were presented and/or created by persons who were not employees of RE.

# 2017 NO<sub>x</sub>-Combustion-CCR Round Table

Feb 27-28, 2017  
Cleveland, Ohio

## SNCR Retrofits for Cost-Efficient NO<sub>x</sub>-Control – International Case Studies and Experiences

Dr.-Ing. Wolfgang Schüttenhelm, ERC Emissions-Reduzierungs-Concepte GmbH, Germany

# Contents

## 1. Introduction

## 2. ERC SNCR Technology

## 3. Reference Case Studies

- **Matra Power Plant, Hungary**

- **Belchatow Power Plant Unit 3, Poland**

- **Yangcheng Power Plant, China**

## 4. Summary

# ERC Emissions-Reduzierungs-Concepte GmbH



**Headquarters: Buchholz i. d. Nordheide / Germany**

**Production site Additives: Wahlstedt / Germany**

**Associated companies outside Germany: ERC s. r. o. Prague / Czech Republic**

**ERC sp. z o.o. Szczecin / Poland**

**ERC Chemtrols Ltd. / Mumbai, India**

**ERC Beijing / China**

**Germany – ERC GmbH,  
ERC Technik GmbH, ERC Additiv GmbH, ERC MSR GmbH**

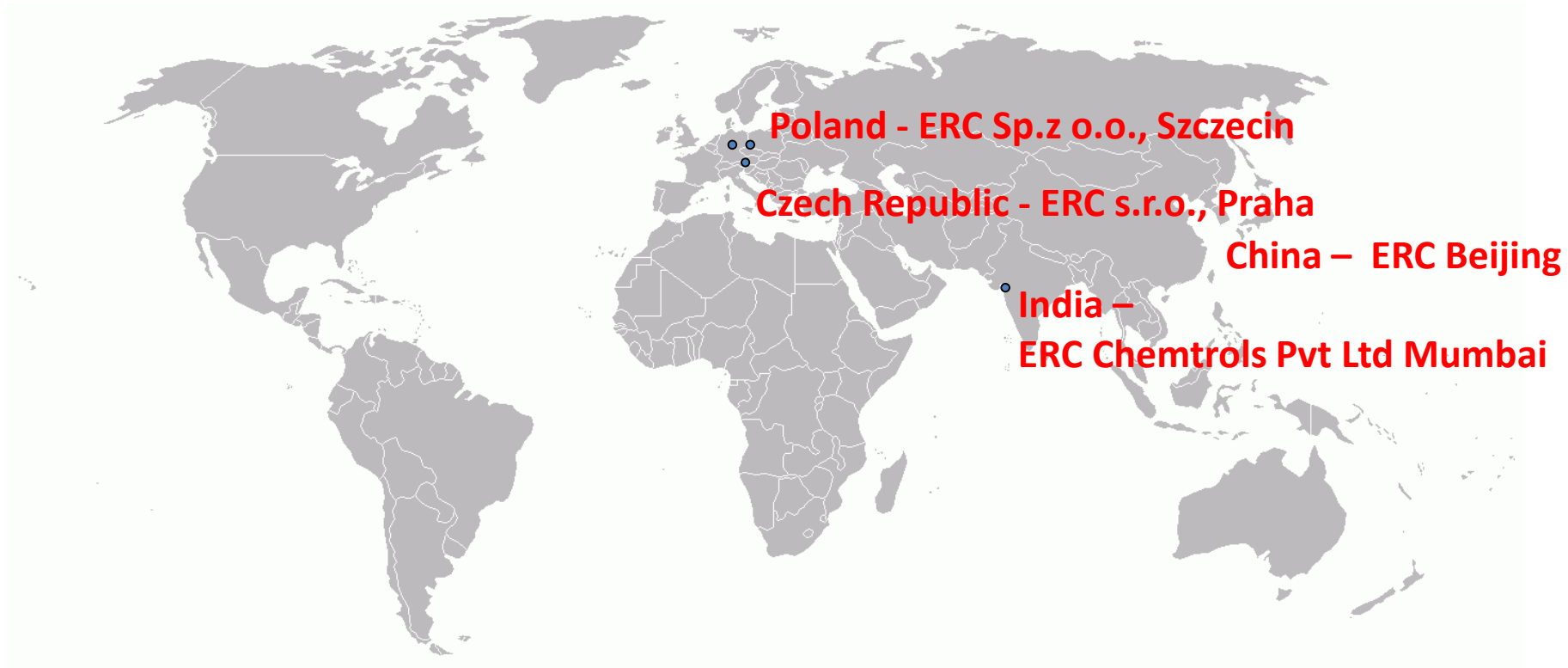

**References on all Continents**

# ERC Technik GmbH - Products

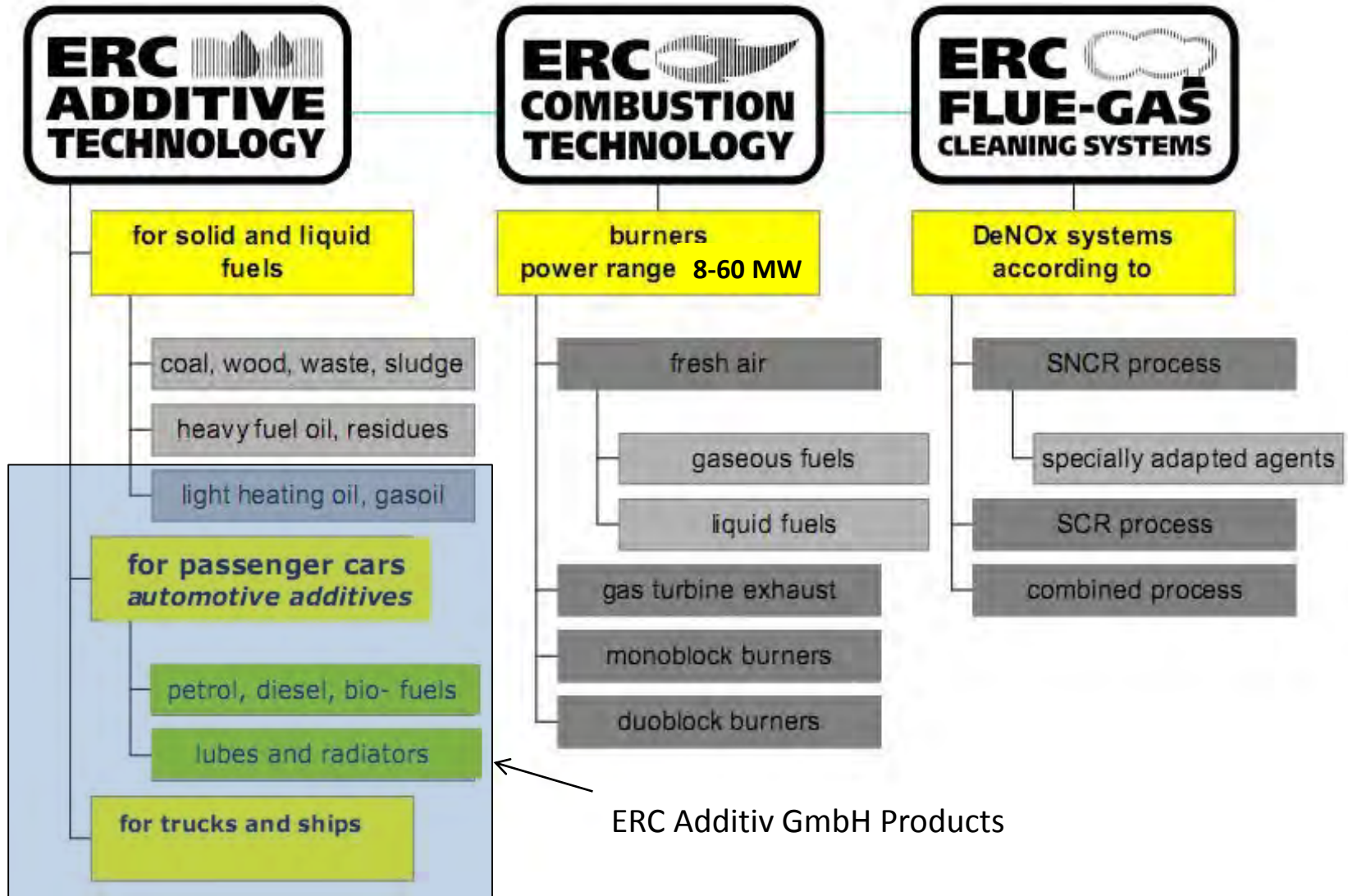

**NO<sub>x</sub>-Reduction for Coal-Fired  
Power Plants**



**Waste and Biomass  
Incineration**



Waste-to-Energy Facility Magdeburg, Germany

**NO<sub>x</sub>-Reduction for  
Cement Plants**



SNCR Reference Holcim Dotternhausen

# 1. Introduction

## Driving Forces promoting SNCR in Europe and Asia

- More stringent emission guidelines
- Age of the fleet / restricted remaining lifetime
- Policy of increasing the share of renewable energy sources
- Restricted operational time per year – large overcapacities
- Increased part load factors
- Lower CAPEX compared to SCR
- Less industrial customers requiring steam and heat (Eastern Europe)
- Decentralized heat supply
- Co-Firing of biomass or switching to biomass completely
- High-ash concentrations / erosion of catalysts

# 1. Introduction: International NO<sub>x</sub> Emission Limits for Large Combustion Plants (I)

## EC Directive 2001/80/EG

Year	Until 31.12.2015	From 01.01.2016	From 2021/22 Expected 1)
NO <sub>x</sub> limit / daily av. [mg/Nm <sup>3</sup> , dry, 6%O <sub>2</sub> ]	< 500 exist. < 200 new	< 200	< 150 bit. coal < 175 lignite
[Lb / MBtu]		< 0.13 bit. Coal < 0.15-0.22 lignite	< 0.1 bit. Coal < 0.13-0.18 lignite

1. Revision of BREF (Best Available Technologies Reference Emission Values, Sevilla Process – 4 years transition time from Summer 2017

## 13. BImSchV, Germany, May 02, 2013

Year	From 01.01.2016	From 01.01.2019	From 2021/22 Expected
NO <sub>x</sub> limit / daily av. [mg/Nm <sup>3</sup> , dry, 6%O <sub>2</sub> ]	< 200 lignite < 150 others	< 100 new (annual average)	< 150 bit. coal < 175 lignite
[Lb / MBtu]	< 0.1 bit. Coal < 0.15 lignite	< 0.065 bit. Coal < 0.08 lignite	< 0.1 bit. Coal < 0.13 lignite

# 1. Introduction: International NO<sub>x</sub> Emission Limits for Large Combustion Plants (II)

New Notification for Thermal Power Plants in India, dated December 7, 2015

Existing boilers	Start until 31.12. 2003	Start until 31.12. 2016
NO <sub>x</sub> limit / daily av. [mg/Nm <sup>3</sup> ,dry/ppm,6%O <sub>2</sub> ]	< 600	< 300
New boilers (Started-up from 01.01.2017 and those ones under construction)		
NO <sub>x</sub> limit / daily av. [mg/Nm <sup>3</sup> ,dry/ppm,6%O <sub>2</sub> ]		< 100

## Lower Emission Limits for Thermal Power Plants in China

Existing and new boilers	Start until 2016	Start from 2016 / 2017
NO <sub>x</sub> limit / daily av. [mg/Nm <sup>3</sup> ,dry/ppm,6%O <sub>2</sub> ]	< 100	< 50
[Lb / MBtu]	< 0.65 bit. coal	< 0.33 bit. coal

# Approach to meet the new EC NO<sub>x</sub> Emission Limit of 200 mg/Nm<sup>3</sup> (approx. 0.13 lb/mmBtu for bit. Coal)

- Primary Measures:**
- Optimization of mills
  - Optimization / Retrofit of burners
  - Staged Combustion
  - Overfire Air
  - Optimization of the firing control system
  - Combustion additives

**Target:** NO<sub>x</sub> Reduction to 250 - 350 mg/Nm<sup>3</sup>

## **Secondary Measures: SNCR (Selective Non Catalytic Reduction)**

**Target:** NO<sub>x</sub> Reduction to < 200 mg/Nm<sup>3</sup>

**If SNCR not applicable, apply SCR**

# Benefits of the SNCR-Process for Large Combustion Plants

- In combination with primary measures the new EC NO<sub>x</sub> emission limit of < 200 mg/Nm<sup>3</sup> / 0.13 lb/MMBtu can be met
- SNCR is not requiring additional space for e. g. structures, reactor and ductwork
- Pressure drop of catalyst have not to be anticipated which in many cases offsets operational cost for compressed air and increased amount of reduction agent
- No requirement of modifications of existing equipment (e. g. ductwork, ESP, fan) due to increased pressure drop
- No risk of catalyst poisoning or erosion resulting in high catalyst management cost – especially when burning lignite or biomass
- Urea based SNCR systems do not require hydrolysis systems to externally produce ammonia
- Much lower CAPEX compared to SCR

# SNCR Technology for Power Plants

## Process Overview

Reduction Agent:  
Carbamin 5722 (doped urea 40%)

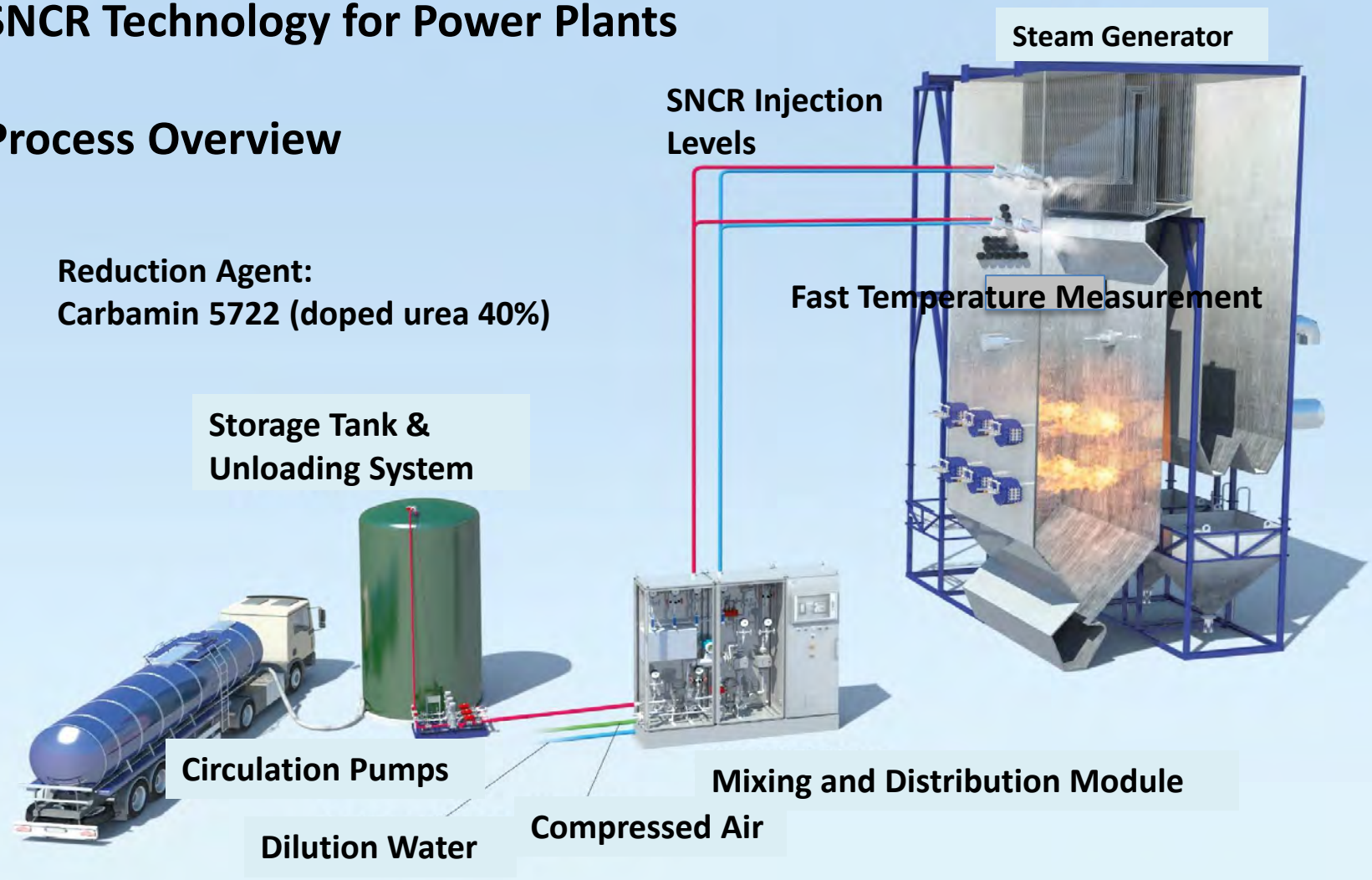

# BASICS OF NO<sub>x</sub>- REDUCTION (I)

## OVERALL REACTION WITH UREA



## DECOMPOSITION



## RADICAL FORMATION

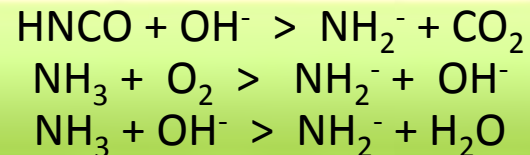

## DEGRADATIVE REACTION



# BASICS OF NO<sub>x</sub>- REDUCTION (II)

## Undesired Reactions / Parallel Reactions

### NH<sub>3</sub> Oxidation



### NO<sub>x</sub>-Formation



### CO Oxidation



### Ammonia Sulfate & Ammonia Hydrogen Sulfate Formation

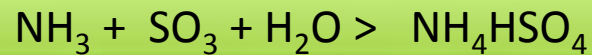
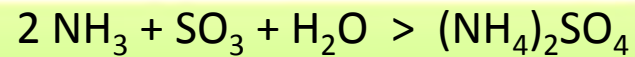

# Typical SNCR NOx Reduction versus Ammonia Slip

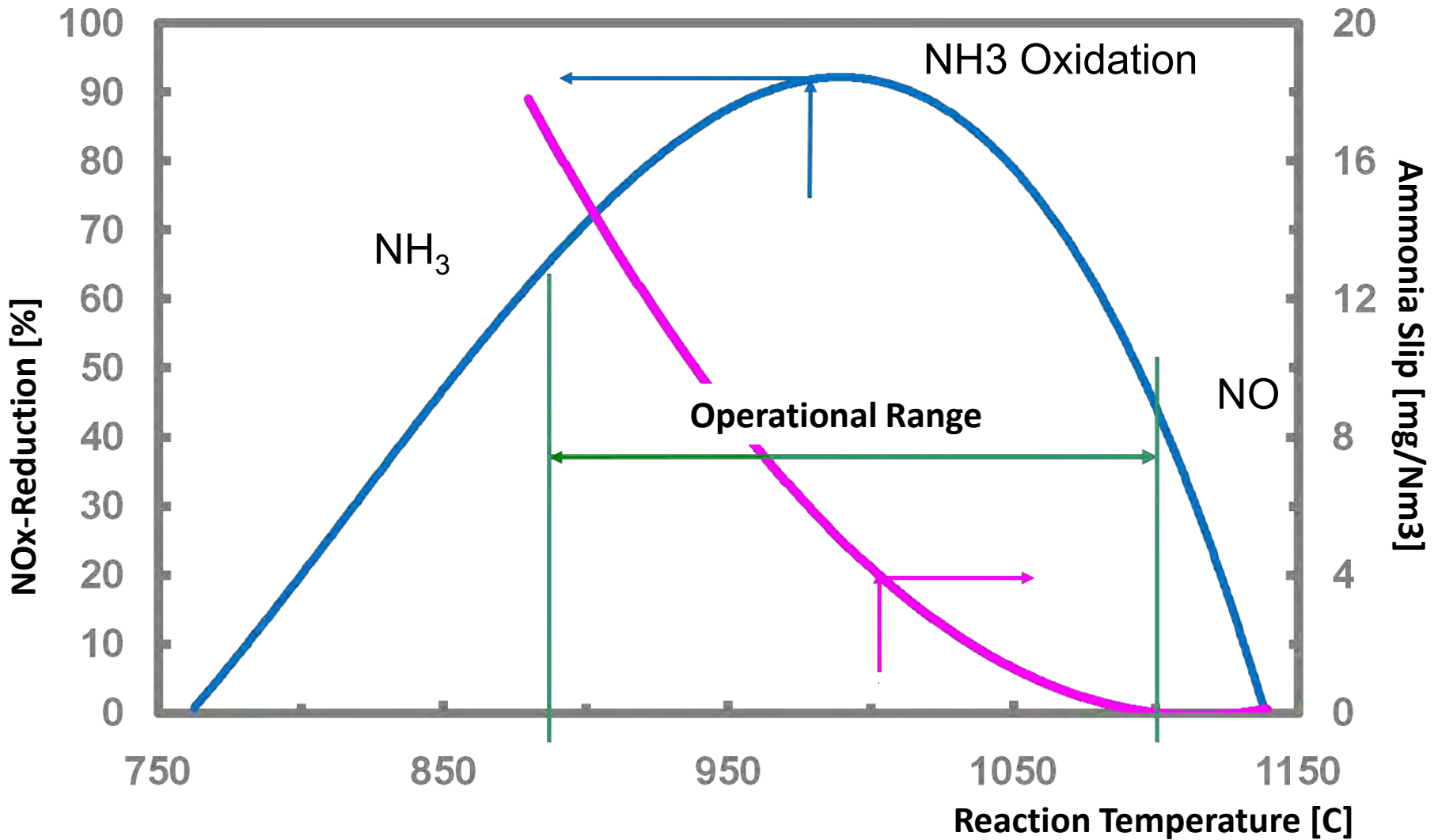

# SNCR Performance & Reagent Consumption

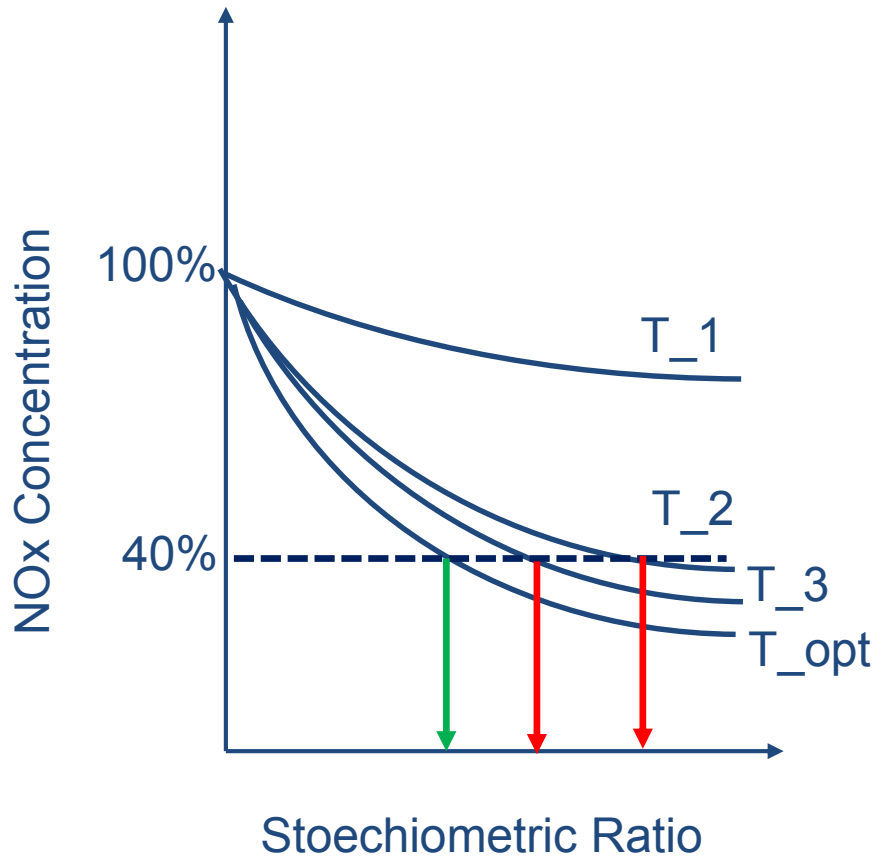

The required NO<sub>x</sub> performance and stoichiometric ratio of reduction agent to NO<sub>x</sub> depends on:

- Flue gas temperature
- Required reduction efficiency
- Permissible ammonia slip
- CO concentration
- O<sub>2</sub> concentration
- Residence time (flue gas velocity) in the SNCR temperature window
- **Precondition: appropriate design of injection points, injection lances / nozzles as well as control concept**

# Spray of ERC Proprietary SNCR Nozzles for Large Combustion Plants



# Position of Lances and Temperature Measuring System

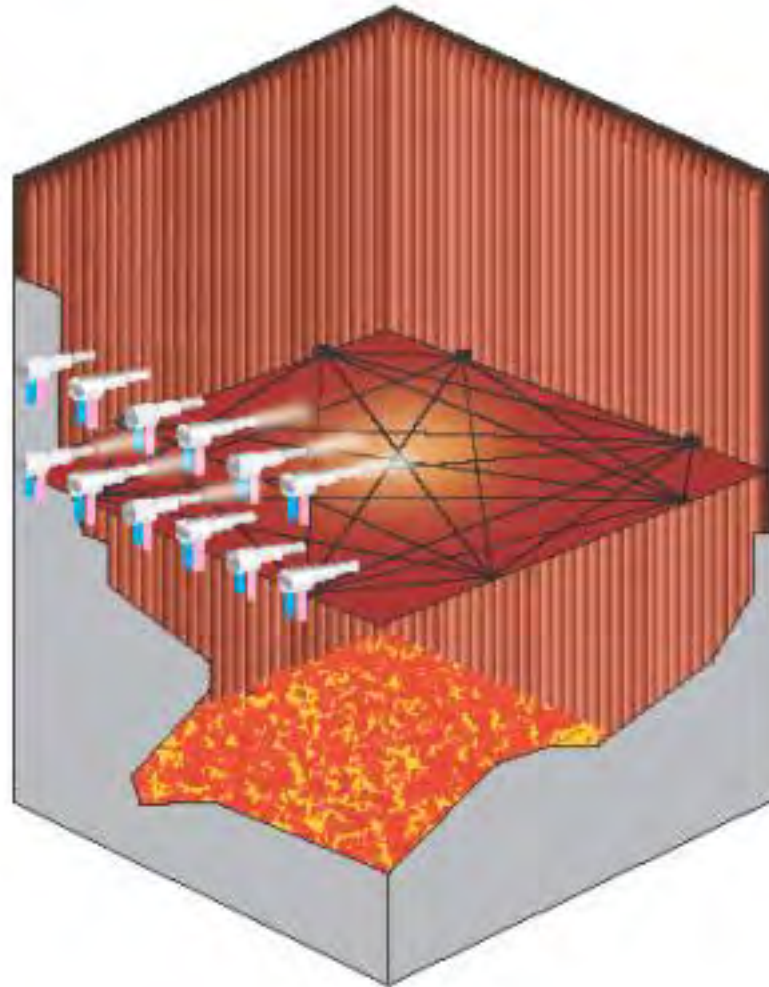

# Temperature Measurement and Injection Control – Split of the Combustion Cross Section in Temperature Zones

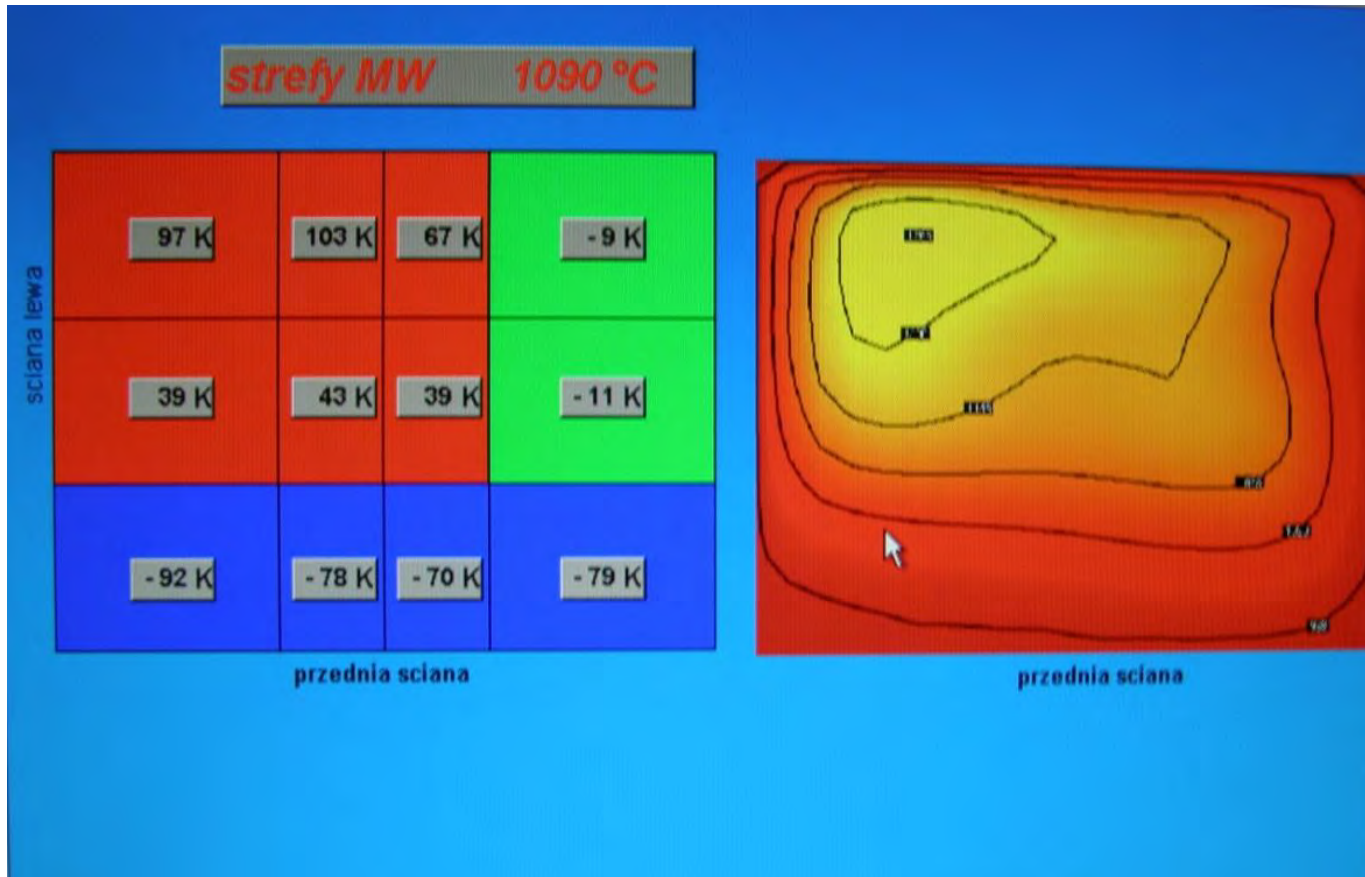

# Key Elements of ERC's SNCR Technology for Large Combustion Plants

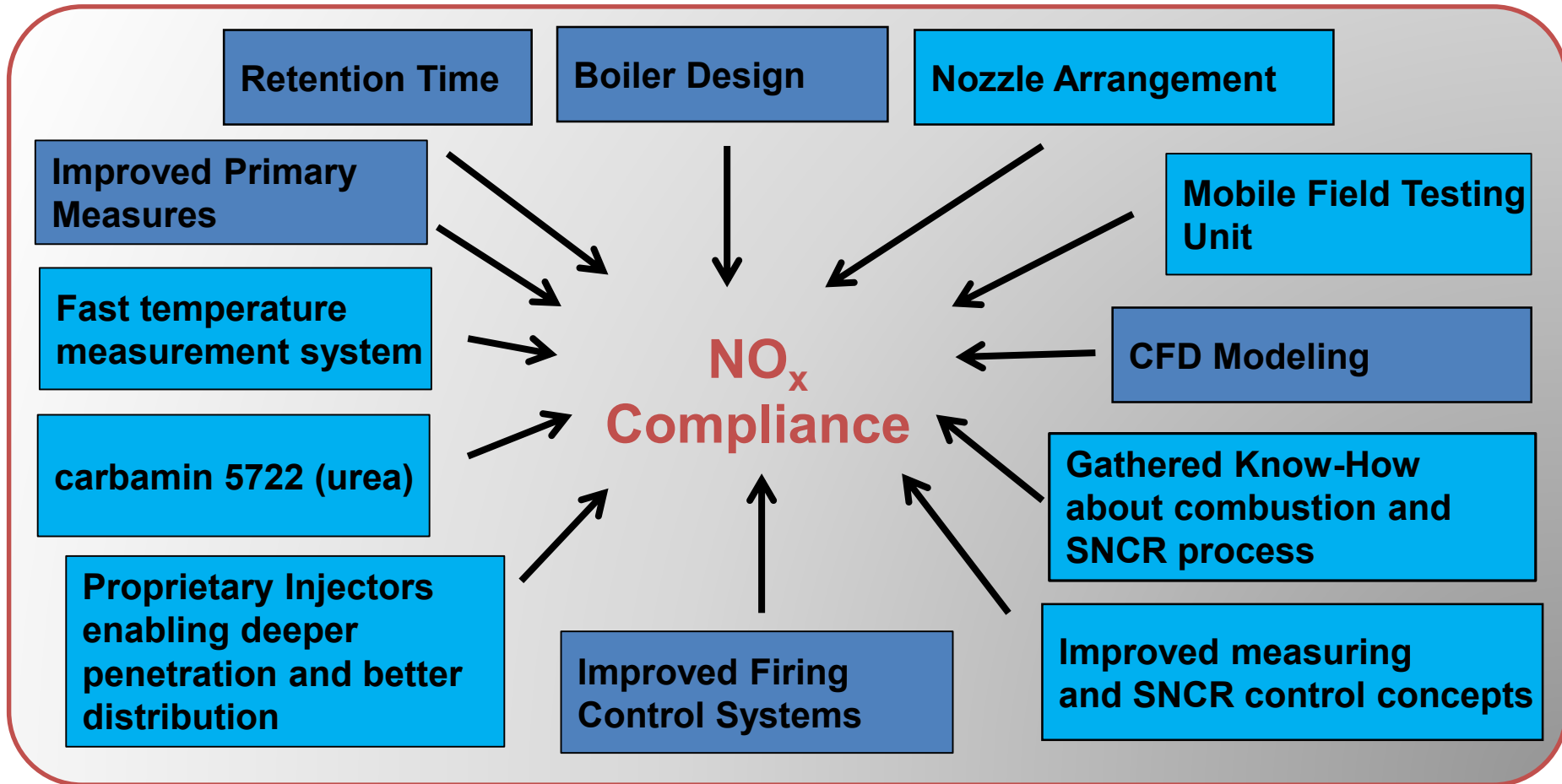

## NO<sub>x</sub>-Reduction of Coal-Fired Power Plants



# Mátrai Erőmű Visonta / Hungary



NOx Emissions reduced below the new EC Limit Value at all of the 5 Units in only 2.5 years

## Reference Plant Introduction

### Worth to be known:

- Largest Hungarian Lignite-Fired Power Station
- Supplies approx. 15 % of Hungary's Electricity (approx. 6200 GWh/a)
- 5 Units commissioned 1969 – 1972
- Total installed capacity: 950 MW<sub>el</sub>
  - Units no. 1, 2: 100 MW<sub>el</sub> each
  - Units no. 3, 4, 5: 220 MW<sub>el</sub> each
  - 2 gas turbines: 45 MW<sub>el</sub> each
- Fuel: Lignite from adjacent surface mining

# Matra Unit III, Design Data

Estimation of Heat Input				
Coal Source	Visonta 2, Open Lignite Mining			
Calorific Value	7164 kJ/kg	3250 kJ/lb	3080 Btu/lb	
Capacity	220 MW <sub>el</sub>			
Steam Production	670 metric t/h	540°C, 140 bar(g)	Enthalpy	3448 kJ/kg
	738.7 stons/h			
eta <sub>th</sub>	90%			
Heat Input	2,566,844 MJ/h	corresponding steam production		
	2432.9 MMBtu/h	713,0	MW <sub>th</sub>	
Coal mass flow rate	358.3 t/h			
Estimation of NOx mass flow rate depending on heat input				
Flue Gas Volume	1,154,040 Nm <sup>3</sup> /h @ 6% O <sub>2</sub> , dry basis		729,004 scfm @ 6% O <sub>2</sub> , dry	
				NOx Reduction
Baseline NOx, average	300 mg/Nm <sup>3</sup>	763,27 lb/hr	0.314 lb/MMBtu	33,3%
Baseline NOx, max	350 mg/Nm <sup>3</sup>	890,48 lb/hr	0.366 lb/MMBtu	42,9%
Clean Gas NOx	200 mg/Nm <sup>3</sup>	508,84 lb/hr	0.209 lb/MMBtu	

## Matra Units 3 – 5, Warranties

**Reduction Agent to be used to meet warranties: Carbamin 5722 (Urea Based)**

**NO<sub>x</sub> < 200 mg/Nm<sup>3</sup>, @ 6 Vol. % O<sub>2</sub>, dry 1)  
approx. 0.209 lb/MMBtu**

**NH<sub>3</sub> < 5 mg/Nm<sup>3</sup>, @ 6 Vol. % O<sub>2</sub>, dry 1)  
approx. 6.58 ppm**

**NH<sub>3</sub> in Ash < 100 mg/kg (100 ppm by wt.)**

**NH<sub>3</sub> in Gypsum < 10 mg/kg (10 ppm by wt.)**

**1) Measured at the emission monitoring system downstream of the ESP**

## **History SNCR Project Matra Units 3 - 5**

<b>Trial / Testing SNCR at Unit 3:</b>	<b>November 2011</b>
<b>Pre-Engineering SNCR Unit 3 &amp; Storage Sytem:</b>	<b>April 2013</b>
<b>Contract SNCR Unit 3, Options for Units 4 - 5:</b>	<b>Juni 2013</b>
<b>Commissioning of Unit 3:</b>	<b>December 2013</b>
<b>Outages Unit 5 &amp; Unit 4:</b>	<b>April 2014 / May 2014</b>
<b>Commissioning of Units 4 &amp; 5:</b>	<b>August 2014</b>
<hr/>	
<b>Commissioning of Units 1 &amp; 2:</b>	<b>2015 / 2016</b>

# SNCR – Reference Matrai, Ungarn

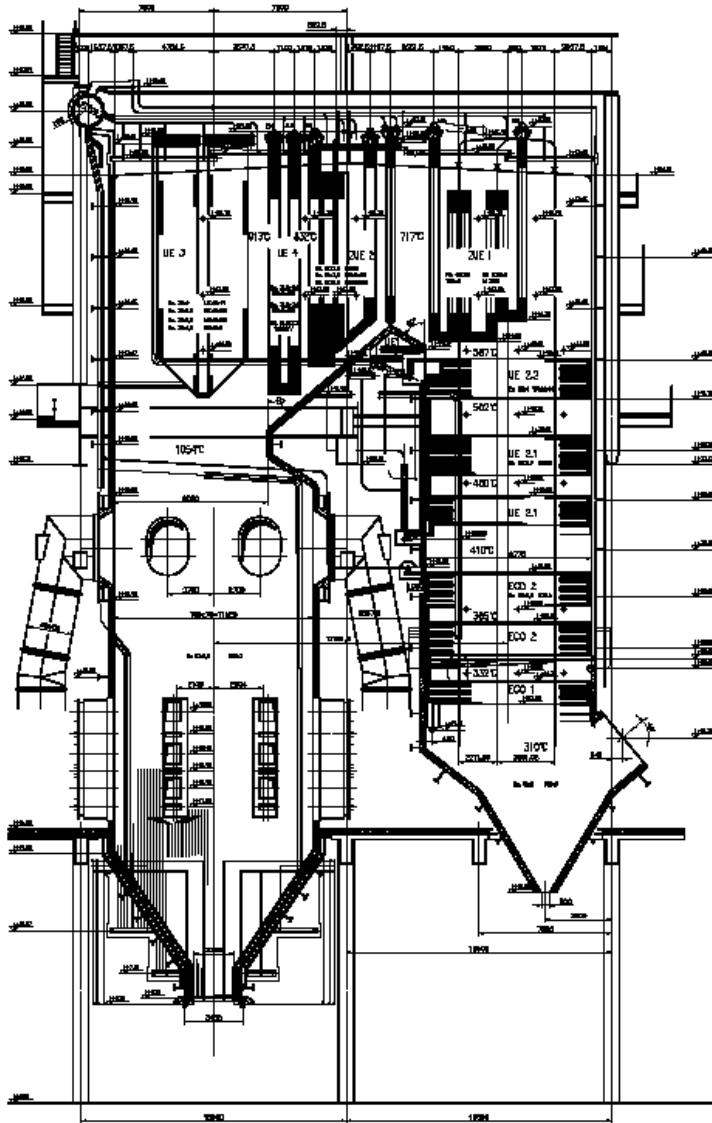

## Unit III, Design Data

**Manufacturer:** Babcock

**Steam Production:** max. 670 t/h

**Steam Temperature:** 540 °C

**Steam Pressure:** 140 bar(g)

**Fuel:** Lignite & Biomass (max. 10%)

**Boiler Load:** min. 110 Mw<sub>el</sub>  
max. 220 MW<sub>el</sub>

**Flue Gas Volume:** min. 800,000 Nm<sup>3</sup>/h  
(dry, 6 % O<sub>2</sub>) max. 1,300,000 Nm<sup>3</sup>/h

**NO<sub>x</sub>-Emission:** approx. 300 mg/Nm<sup>3</sup> dry, 6 % O<sub>2</sub>  
max. 350 mg/Nm<sup>3</sup> dry, 6 % O<sub>2</sub>

## Arrangement of Mills and Burners

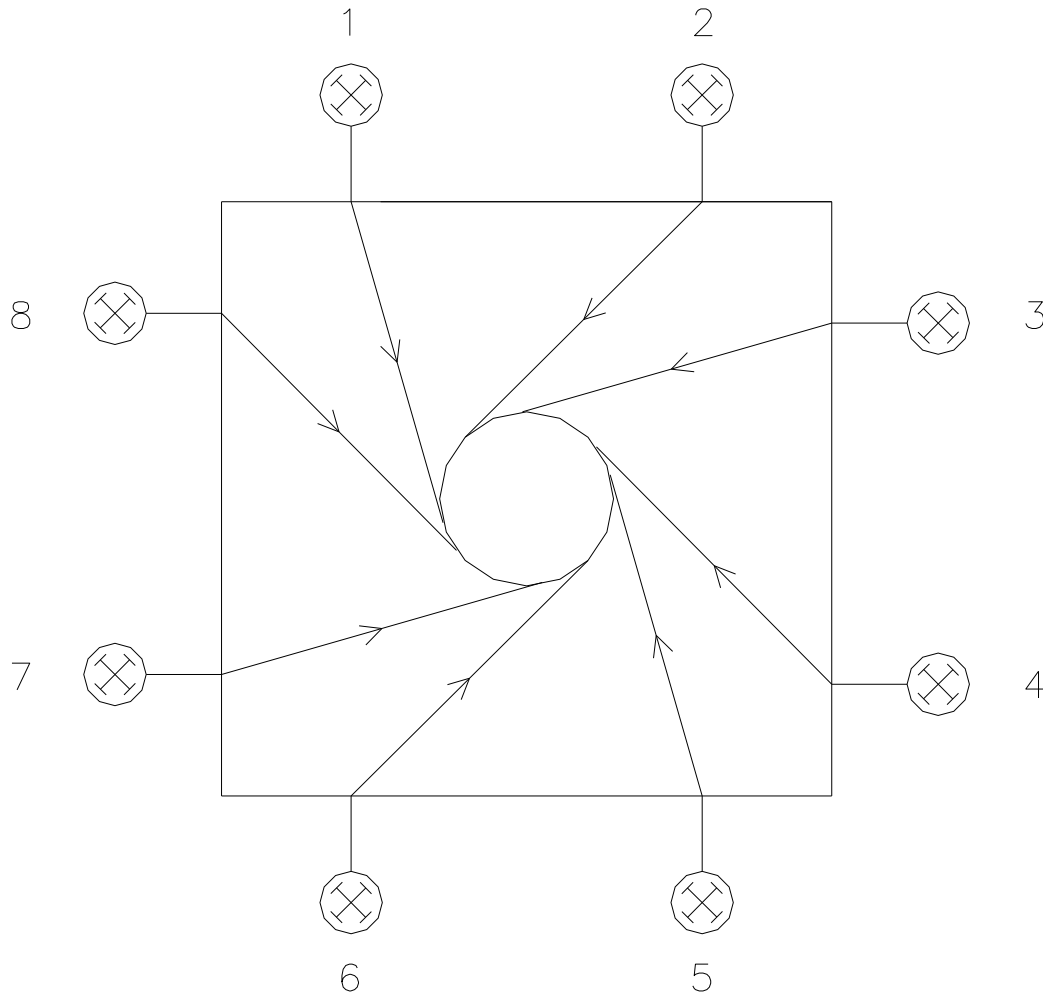

### SNCR Trial at Unit 3

Targets:

NO<sub>x</sub>: < 200 mg/Nm<sup>3</sup>, at 6 % of vol. O<sub>2</sub>, dry <sup>1)</sup>

NH<sub>3</sub> slip: < 5 mg/Nm<sup>3</sup>, at 6 % of vol. O<sub>2</sub>, dry <sup>1)</sup>

NH<sub>3</sub> in the ash: < 100 mg/kg

NH<sub>3</sub> in the gypsum: < 10 mg/kg

reduction agent: carbamin 5722 (urea based)

<sup>1)</sup> measured with the emission monitoring system, downstream ESP

## CFD Simulation of Temperature Distribution at Unit 3

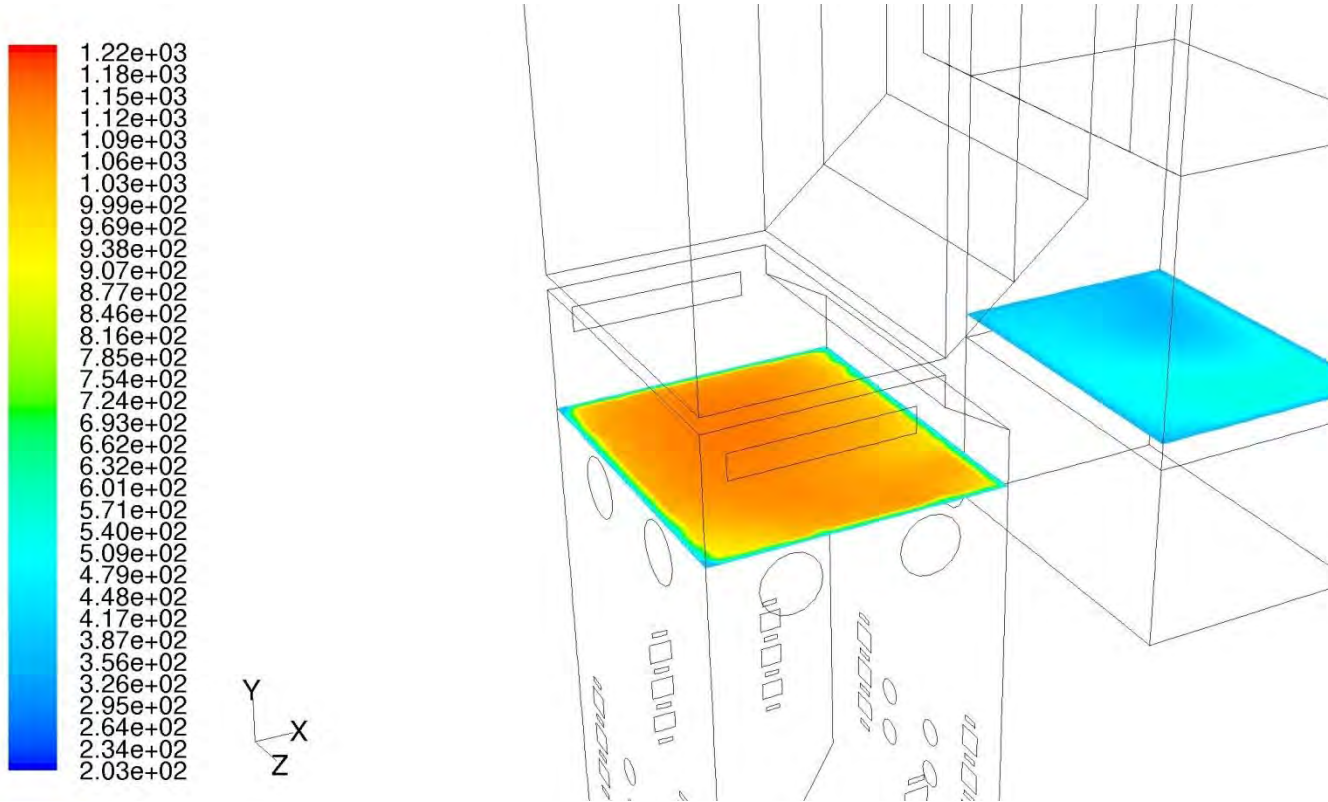

## Temporary Storage for NO<sub>x</sub> Reduction Agent



NO<sub>x</sub> reduction agent: carbamin 5722, urea based

## SNCR Testing Equipment



## Injection Lances



left



right



front left



front right

# SNCR – Reference Matrai, Ungarn

## Test Results at 110 MW<sub>el</sub>, 175 MW<sub>el</sub> and 220 MW<sub>el</sub>

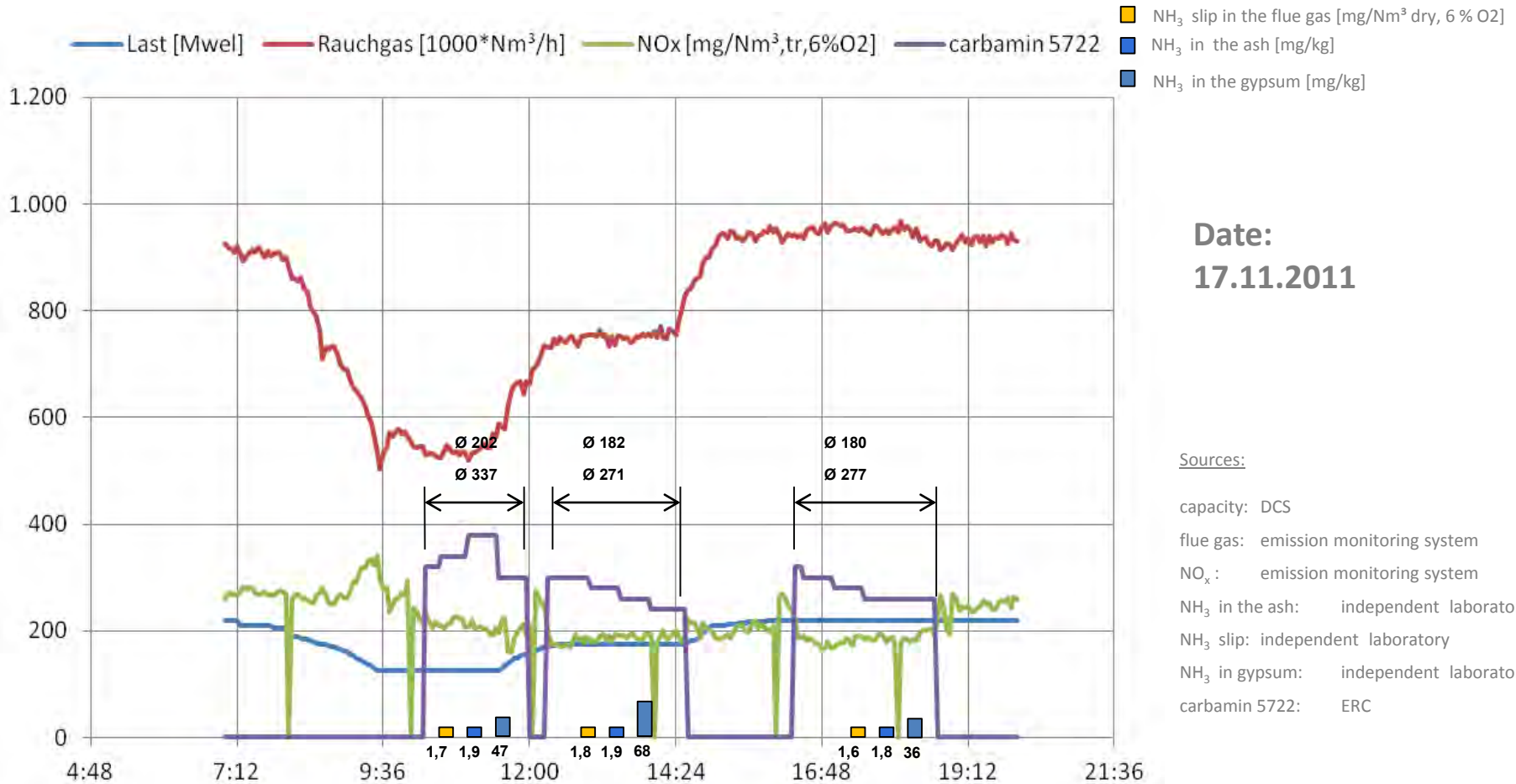

Date:  
17.11.2011

Sources:

- capacity: DCS
- flue gas: emission monitoring system
- NO<sub>x</sub>: emission monitoring system
- NH<sub>3</sub> in the ash: independent laboratory
- NH<sub>3</sub> slip: independent laboratory
- NH<sub>3</sub> in gypsum: independent laboratory
- carbamin 5722: ERC

## Main Equipment of the Commercial SNCR Plant

<u>Component</u>	<u>No. of pieces</u>	<u>Remarks</u>
Tanks for NO <sub>x</sub> reduction agent	2	common, volume 100 m <sup>3</sup> / tank
Urea unloading pump station	1	common
Dosing station for carbamin 5100	1	common, incl. storage, volume 1.25 m <sup>3</sup>
Circulation pumps for NO <sub>x</sub> reduction agent	4	common, 2 submersible pumps / tank
Pump station for dilution water	1	common
Mixing and measuring modules	9	3 per unit
Injection lances	72	24 per unit, 2 levels
Temperature measuring systems	3	one per unit, 8 optical pyrometers
Control cabinets	3	one per unit



## Arrangement of the Injection Lances Lower Level, + 35.5 m for Low Loads up to 110 MW<sub>e1</sub>

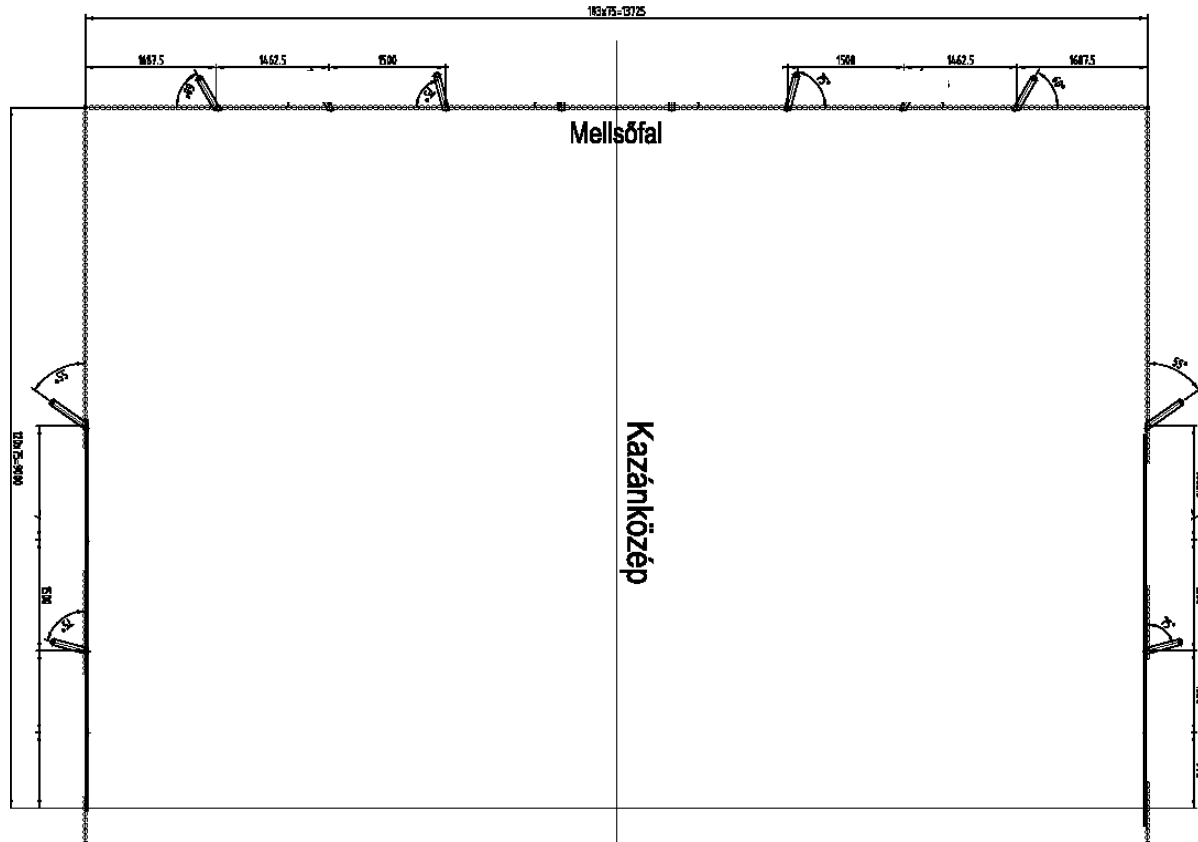

## NO<sub>x</sub> Reduction Agent Storage Plant



## Urea Discharging Pump Station



carbamin 5100 Dosing Station



## Booster Pump Station for Dilution Water



## Injection Lance



Mixing and Distribution Modules Special Design for Extremely Dusty Areas



**Mixing and Distribution Module**  
**for Dilution Water and NO<sub>x</sub> Reduction Agent**



## Distribution Cabinets

for Atomisation Air and Diluted NO<sub>x</sub> Reduction Agent



## Optical Pyrometer



## Furnace Temperature and Combustion Quality Mapping

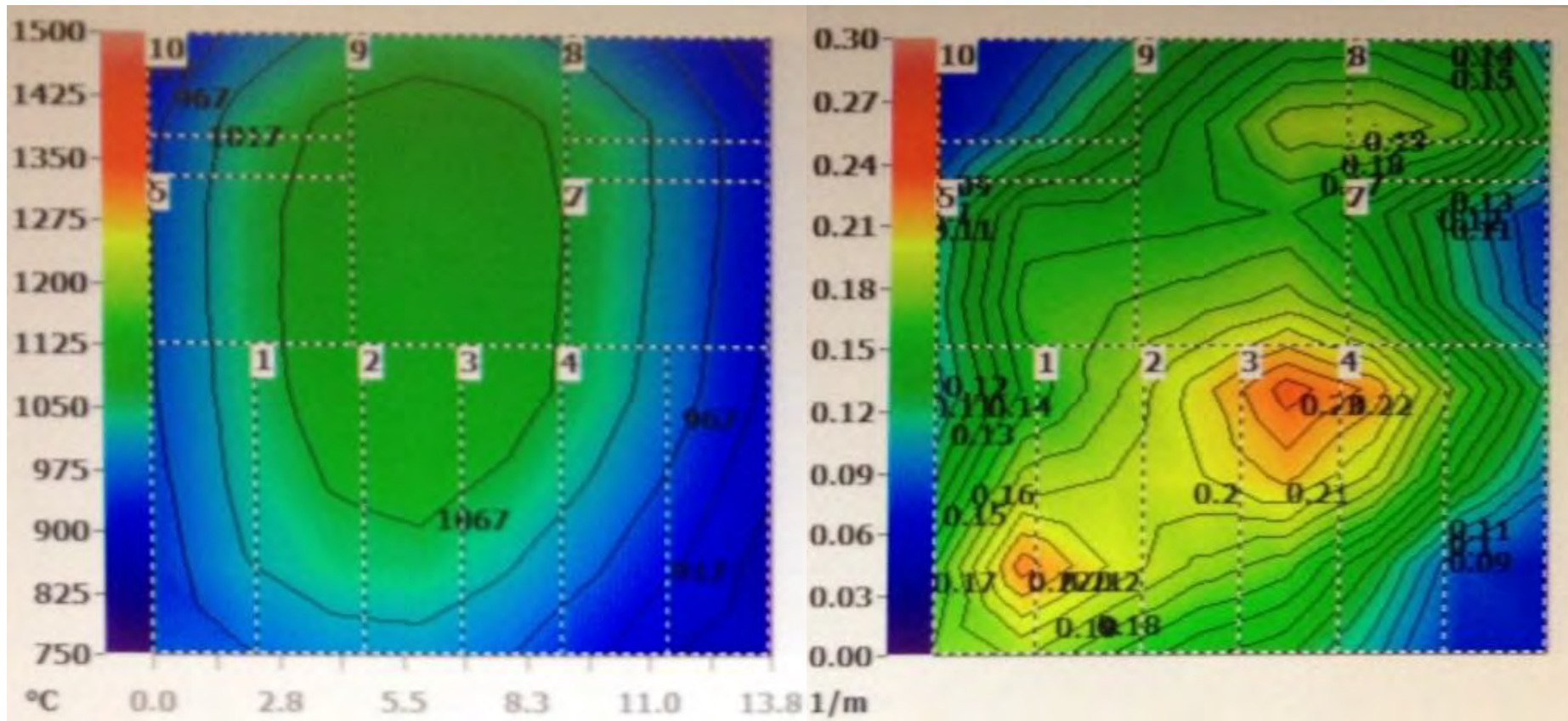

## Control Cabinets: SNCR and Temperature Measuring System



# SNCR – Reference Matrai, Ungarn

## Unit 4: Operational Parameters with the Commercial SNCR Plant

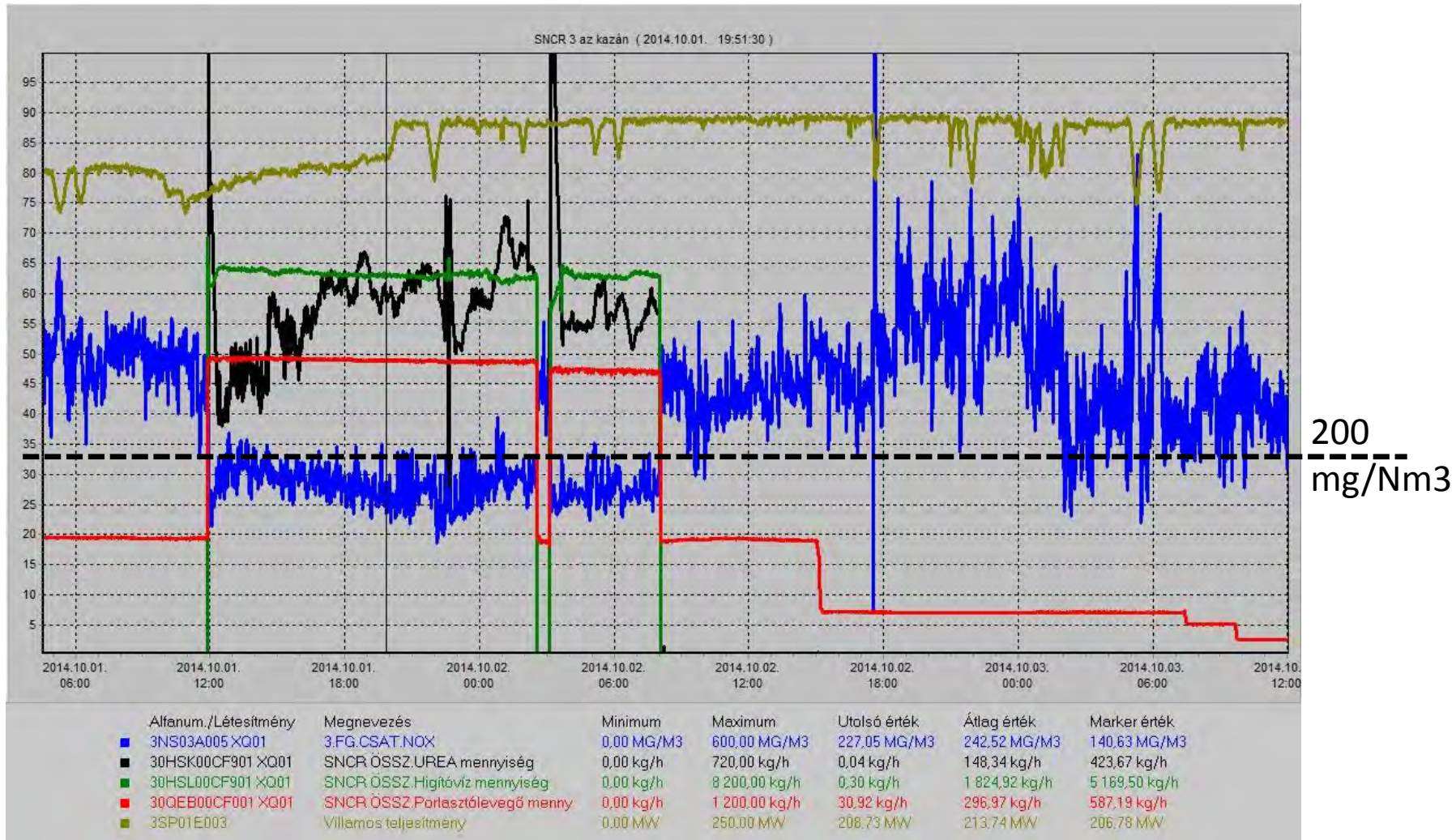

## Elektrownia Bełchatów – World-wide Largest Lignite-Fired Power Plant



Unit 3: 380 MW<sub>el</sub>, approx. 1.5 Mio. Nm<sup>3</sup>/h

Meeting the expected new BREF Emission level of 150 – 175 mg/Nm<sup>3</sup>

## Bełchatów Power Plant

- commissioned in 1981
- located close to Łódź
- largest lignite Power Plant world-wide
- produces more than 1/3 of Poland's electricity
- total capacity of 5420 MW<sub>el</sub>
- 12 Units, steam production 1150 t/h (380 – 390 MW<sub>el</sub>)
- Unit 14, over-critical steam parameters (858 MW<sub>el</sub>), el. Efficiency > 42 %



## Project Time Schedule

<b>Contract Award:</b>	<b>December 2015</b>
<b>Boiler modifications / openings:</b>	<b>Mid February 2016</b>
<b>Supply of SNCR Equipment:</b>	<b>March 2016</b>
<b>Erection:</b>	<b>until End of March 2016</b>
<b>Commissioning:</b>	<b>until End of April 2016</b>
<b>Delays of customer:</b>	<b>until June 2016</b>
<b>Trial Run:</b>	<b>until End of August 2016</b>
<b>Performance Measurements:</b>	<b>September 2016</b>
<b>Hand-over to customer:</b>	<b>End of September 2016</b>

## Design Data

### Design Basis SNCR Unit 3

Max. steam production:	1150 t/h
Load range:	60 – 100 %
Max. fuel mass flow:	460 t/h
Lower Heating Value Guarantee Coal:	7750 kJ/kg / appr. 3700 Btu/lb HHV
Max. Flue Gas Volumetric Flow Rate:	1,445,000 Nm <sup>3</sup> /h (dry, 6 % O <sub>2</sub> )
Max. Flue Gas Temperature End of Combustion:	1086 °C / 2012 °F
<b>NO<sub>x</sub> Base Line:</b>	<b>200 mg/Nm<sup>3</sup> (approx. 0.2 lb/MMBtu)</b>
Target:	$\Delta$ NO <sub>x</sub> $\geq$ 50 mg/Nm <sup>3</sup> NH <sub>3</sub> Slip $\leq$ 5 mg/Nm <sup>3</sup> NH <sub>3</sub> in Ash $\leq$ 100 mg/kg



## Boiler Modifications



SNCR Equipment



Dosing and Mixing Module

Valve Station for Injector Control



SNCR Equipment

Injection Lances

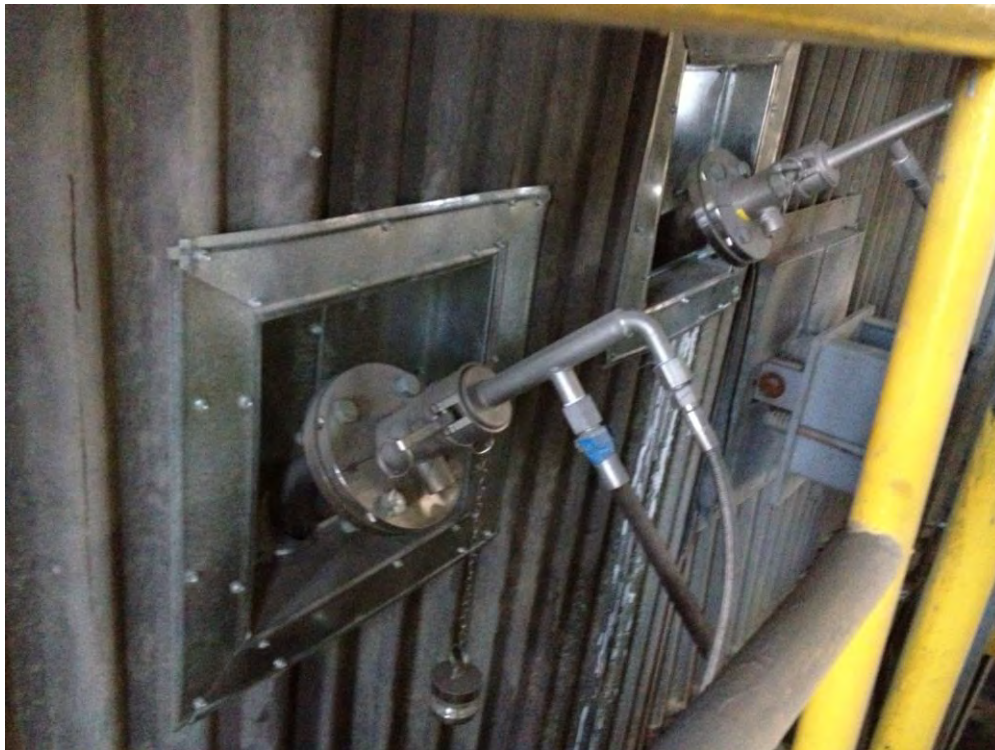

Optical Pyrometer and Shock Blower



# Online Temperature Measurement

## Temperature Field and Optical Flue Gas Density

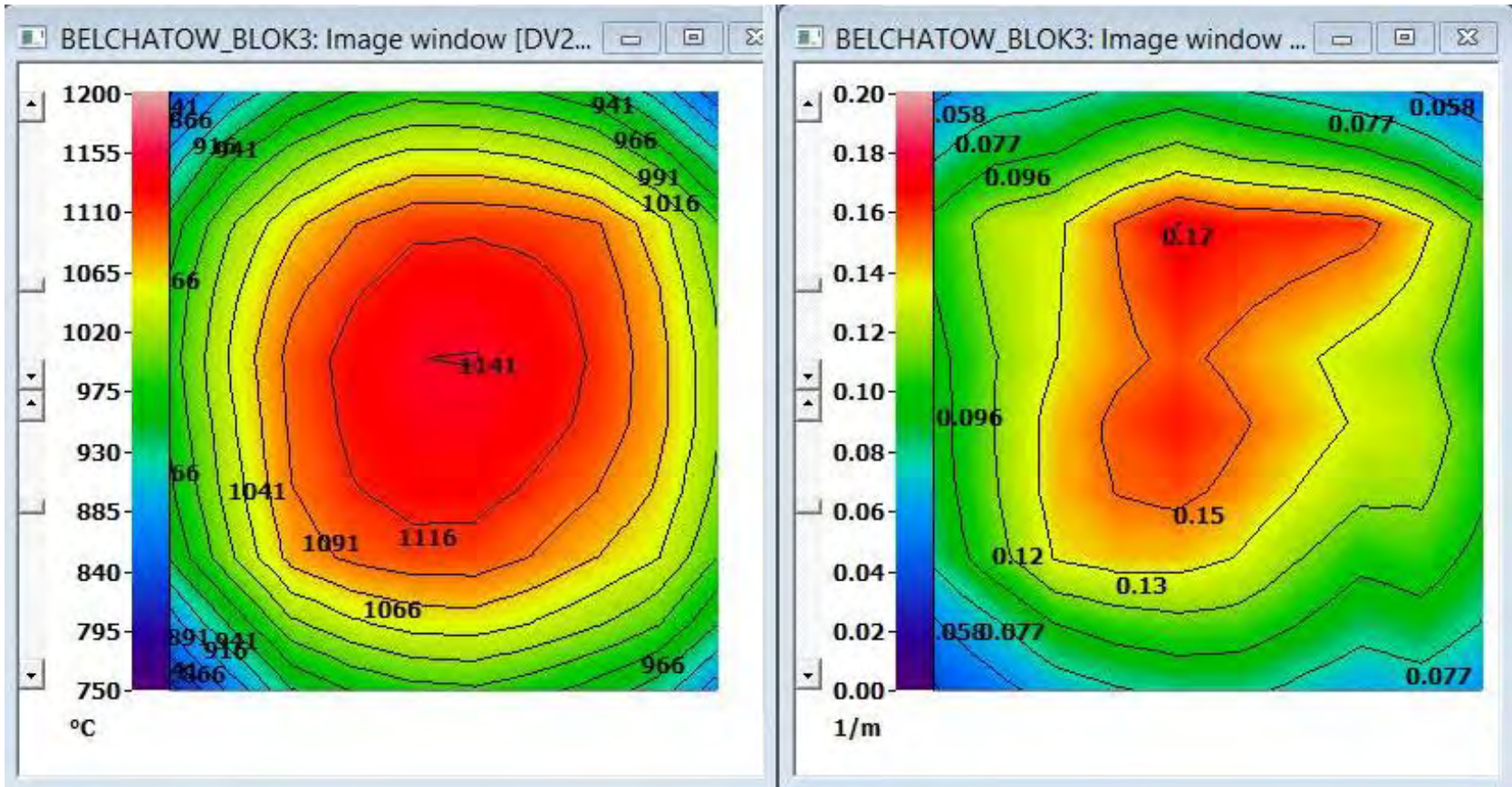

# Injectors and Temperature Field

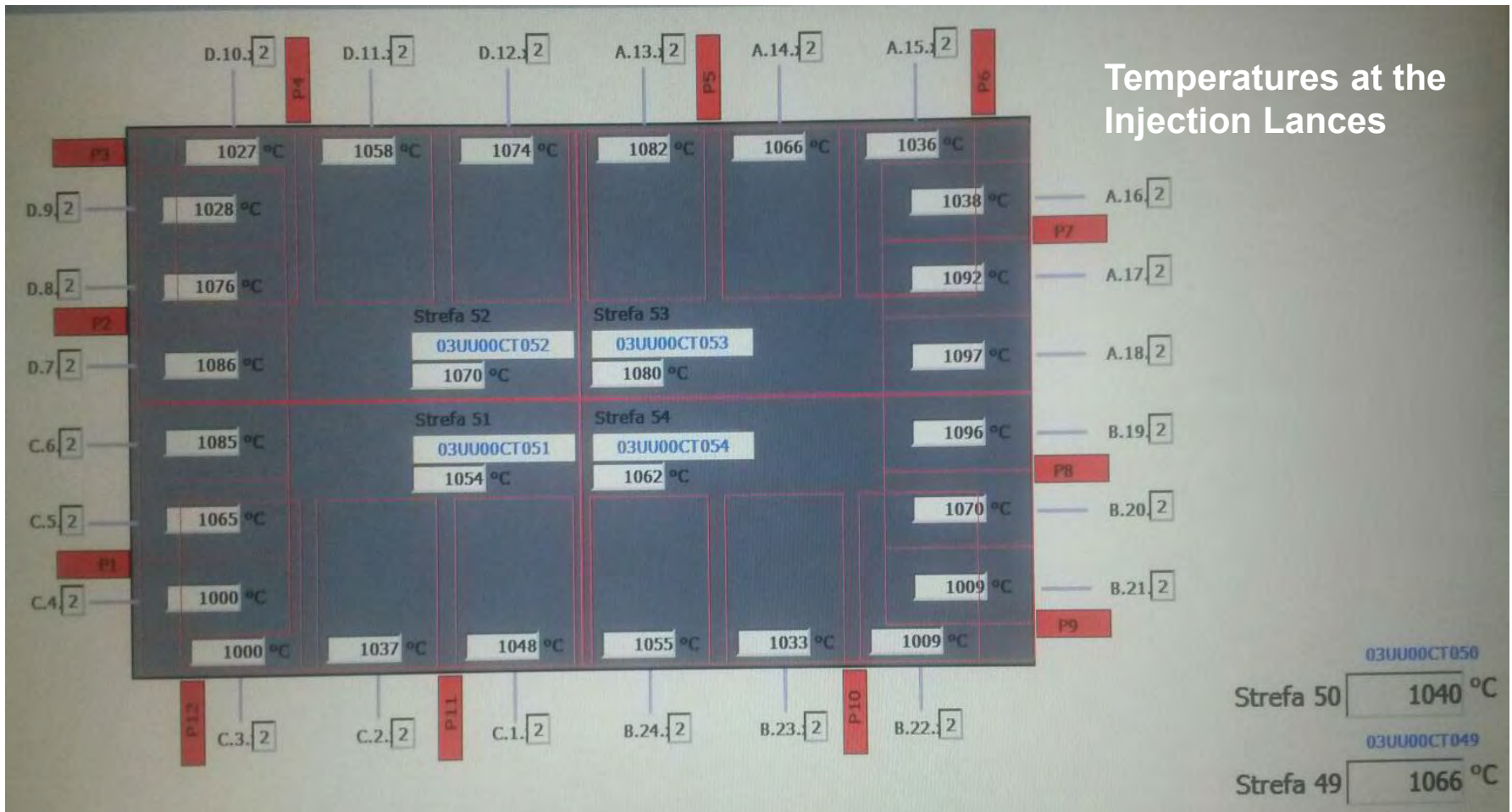

## Instrumentation and Control

### In Situ $\text{NH}_3$ Measuring Device upstream of Air Preheater



# Operational Results

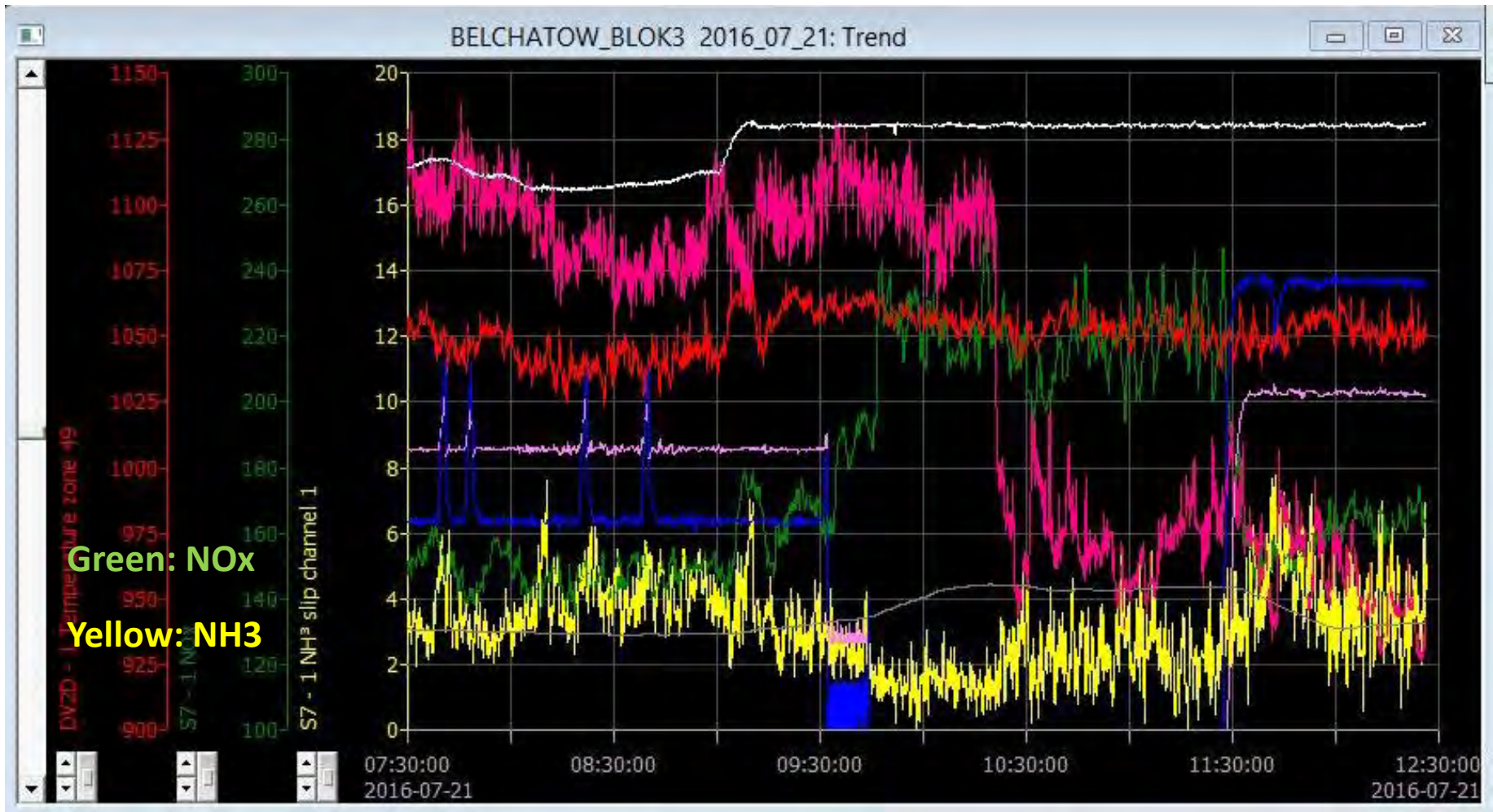

## Yangcheng Power Station, China



Unit 1 - 6: 350 MW<sub>el</sub>      Unit 7 - 8: 600 MW<sub>el</sub>

**NO<sub>x</sub> Emissions reduced below 50 mg/Nm<sup>3</sup> by means of combining SNCR and SCR**

## Design Data SNCR Yangcheng Units 1 - 4

<b>Operation Point</b>	<b>MW</b>	<b>350</b>
Flue gas flow	$\text{m}^3_{\text{n}}/\text{h}$	1,550,000
Flue gas flow (dry)	$\text{m}^3_{\text{n}}/\text{h}$ (dry)	1,410,500
Flue gas quantity (dry)	$\text{m}^3_{\text{n}}/\text{h}$ / scfm @ 6 % $\text{O}_2$ (dry)	1,685,367 / 990,000
$\text{O}_2$ (average/assumed)	Vol.-% (wet)	2.8
$\text{H}_2\text{O}$ (assumed)	Vol.-%	9.0
<b><math>\text{NO}_x</math> emission (baseline), daily average</b>	<b><math>\text{mg}/\text{m}^3_{\text{n}}</math> @ 6 % <math>\text{O}_2</math> (dry)</b>	<b>1000 (approx. 0.65 lbs/MMBtu)</b>
<b><math>\text{NO}_x</math> emission downstream SNCR, daily average</b>	<b><math>\text{mg}/\text{m}^3_{\text{n}}</math> @ 6 % <math>\text{O}_2</math> (dry)</b>	<b>550 (approx. 0.3 lbs/MMBtu)</b>
<b><math>\text{NO}_x</math> emission downstream SCR (existing), daily average</b>	<b><math>\text{mg}/\text{m}^3_{\text{n}}</math> @ 6 % <math>\text{O}_2</math> (dry)</b>	<b>50 (approx. 0.033 lbs/MMBtu)</b>

## Design Data SNCR Yangcheng Units 7 - 8

<b>Operation Point</b>	<b>MW</b>	<b>600</b>
Flue gas flow	m <sup>3</sup> <sub>n</sub> /h	2,000,000
Flue gas flow (dry)	m <sup>3</sup> <sub>n</sub> /h (dry)	1,820,000
Flue gas quantity (dry)	m <sup>3</sup> <sub>n</sub> /h / scfm @ 6 % O <sub>2</sub> (dry)	2,174,667 / 1,280,000
O <sub>2</sub> (average/assumed)	Vol.-% (wet)	2.8
H <sub>2</sub> O (assumed)	Vol.-%	9.0
<b>NO<sub>x</sub> emission (baseline), daily average</b>	<b>mg/m<sup>3</sup><sub>n</sub> @ 6 % O<sub>2</sub> (dry)</b>	<b>1000 (approx. 0.65 lbs/MMBtu)</b>
<b>NO<sub>x</sub> emission downstream SNCR, daily average</b>	<b>mg/m<sup>3</sup><sub>n</sub> @ 6 % O<sub>2</sub> (dry)</b>	<b>550 (approx. 0.3 lbs/MMBtu)</b>
<b>NO<sub>x</sub> emission downstream SCR (existing), daily average</b>	<b>mg/m<sup>3</sup><sub>n</sub> @ 6 % O<sub>2</sub> (dry)</b>	<b>50 (approx. 0.033 lbs/MMBtu)</b>

## Arrangement of SNCR Injection Levels and Online-Temperature Measurement, Units 1 - 4

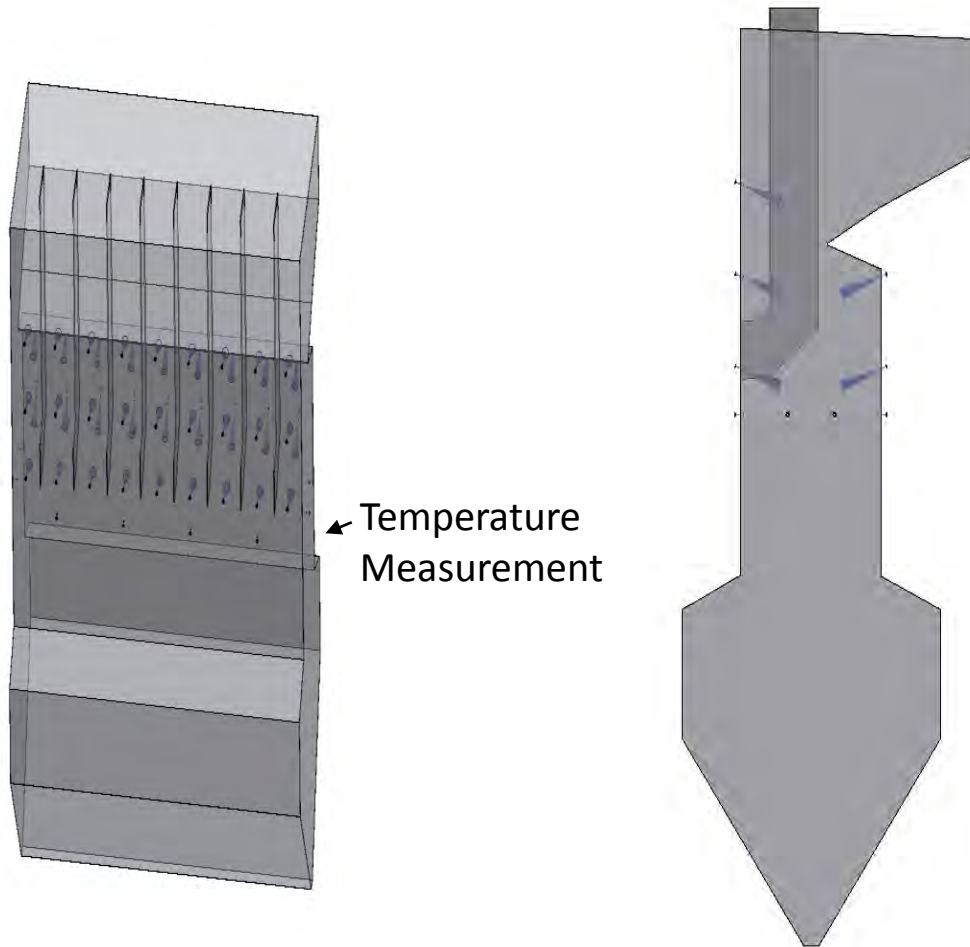

## SNCR – Reference Yangcheng Power Station, China



**Yangcheng Power Station,  
Urea Storage**



## SNCR – Reference Yangcheng Power Station, China



## Yangcheng Power Station Boiler 4, Mixing and Distribution Modules

## SNCR – Reference Yangcheng Power Station, China



**Yangcheng Power Station Boiler 4,  
Injection System**

## Yangcheng Power Station Boiler 4 – SNCR Results

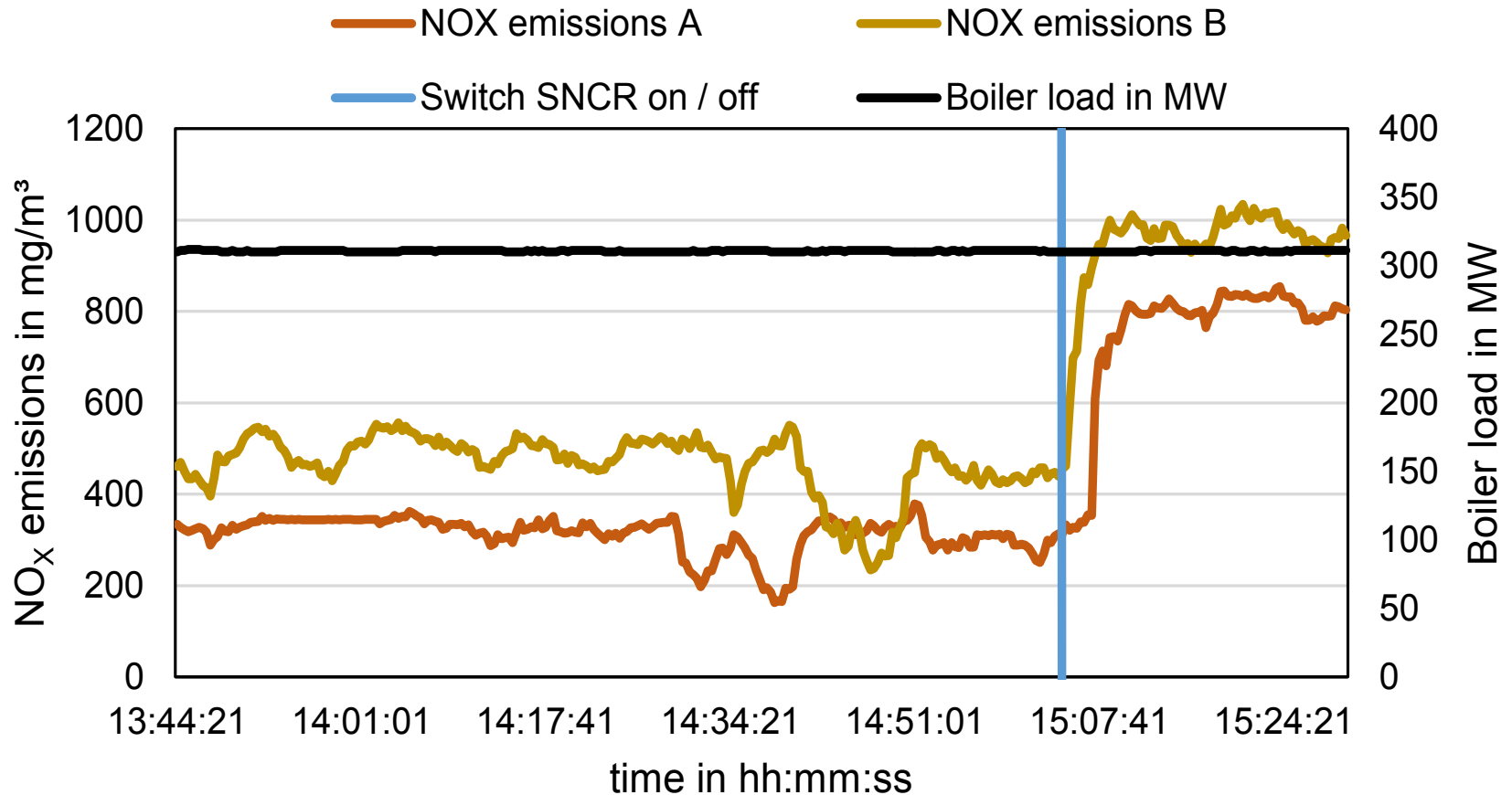

## Yangcheng Power Station Boiler 4 – SNCR Results



NOx downstream  
SNCR & SCR  
(left / right Reactors)

## Dhekelia Power Station Units I – III, Cyprus



**Turn-Key High-Pressure SCR Retrofit downstream 3 x 18 MW<sub>el</sub> Two-Stroke-Engines, Fuel: HFO**

# Summary / Conclusions

- SNCR is an efficient and cost-effective technology for NO<sub>x</sub> control in large power stations
- ERC's proven technology is based on advanced SNCR injection systems in combination with online temperature measurements to achieve a high NO<sub>x</sub> control efficiency and a low ammonia slip
- NO<sub>x</sub> < 200 mg/Nm<sup>3</sup> / 0,13 – 0,2 lb/MMBtu and NH<sub>3</sub> slip < 5 mg/Nm<sup>3</sup> / 6.6 ppm or less are met in combination with modern LNBs
- The presented projects were executed in the agreed time schedule
- The combination SNCR and SCR provides very high NO<sub>x</sub> removal rates while maintaining a very low ammonia slip.
- A urea dissolving plant is a proven means to reduce reduction agent costs and increasing the overall economics
- ERC has gathered a huge experience which will be applied in favor of our customers in order to grant cost-effective compliance



**Thanks for your attention – Questions???**

Dr.-Ing. Wolfgang Schüttenhelm

[wschuettenhelm@erc-online.de](mailto:wschuettenhelm@erc-online.de)

If it wouldn't have worked we had a backup plan ...

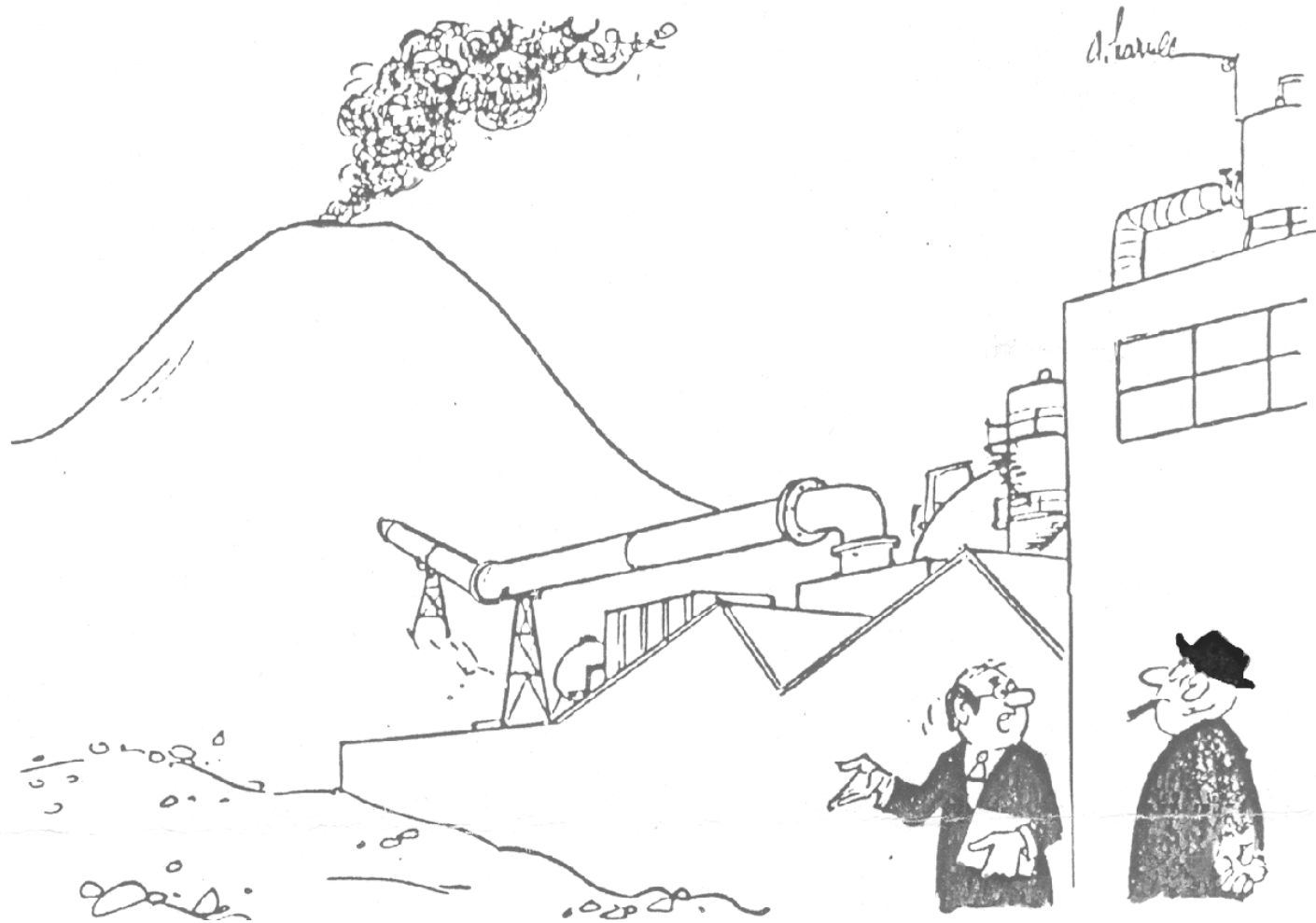

since we lead the flue gas into the crater nobody complains about emissions any more